

**CITY OF LA VISTA
MAYOR AND CITY COUNCIL REPORT
JULY 19, 2016 AGENDA**

| Subject: | Type: | Submitted By: |
|---|-------------------------------------|---|
| APPLICATION FOR PRELIMINARY PLAT, LOTS 1-7, BRENTWOOD CROSSING, LOTS 8B & 8C, BRENTWOOD CROSSING REPLAT NO. 1, LOTS 8A1, 8A2, 8A3 & 8A4, BRENTWOOD CROSSING REPLAT NO. 2, AND PORTIONS OF TAX LOT 12, 14-14-12; AND WAIVER OF SECTION 4.24, SUBDIVISION REGULATIONS (SE OF 84 TH & SUMMER DR.) | ◆ RESOLUTION ORDINANCE RECEIVE/FILE | ANN BIRCH COMMUNITY DEVELOPMENT DIRECTOR |

SYNOPSIS

A resolution has been prepared to approve the Preliminary Plat for approximately 34.93 acres and a waiver of Section of 4.24 of the Subdivision Regulations, regarding the minimum centerline radius of a local street from 200 feet to 100 feet, generally located southeast of 84th Street and Summer Drive.

FISCAL IMPACT

None.

RECOMMENDATION

Approval.

BACKGROUND

A resolution has been prepared to approve the application for the Preliminary Plat of proposed Lots 1 – 17 and Outlots A – C, La Vista City Centre, and a waiver of Section 4.24 of the Subdivision Regulations submitted by La Vista City Centre LLC on behalf of the property owners, Brentwood Crossing Associates, Brentwood Crossing Associates II, and Brentwood Crossing Associates III, generally located southeast of 84th Street and Summer Drive.

The property is currently platted as Brentwood Crossing, site of the former Walmart, Hobby Lobby, Summer Kitchen Café, and various tenant bays. The property also contains lots for First National Bank, Chili’s, the former Kinko’s/FedEx store, McDonald’s, and the former Brentwood Car Wash. Additionally, the replat contains portions of the golf course property abutting the development which are proposed to be sold to the developer. The proposed replatting and the waiver of the minimum centerline street radius will allow for the development of a mixed use city center as identified in *A Vision Plan for 84th Street*.

A detailed staff report is attached

The Planning Commission held a public hearing on June 2, 2016, and unanimously recommended approval of the Preliminary Plat and waiver of Section 4.24 of the Subdivision Regulations as flexibility in the horizontal centerline radii is needed to meet the design for a city center district portrayed within the Vision 84 plan.

RESOLUTION NO. 16-071

A RESOLUTION OF THE MAYOR AND CITY COUNCIL OF THE CITY OF LA VISTA, NEBRASKA, FOR APPROVAL OF THE PRELIMINARY PLAT FOR LOTS 1 THRU 7, BRENTWOOD CROSSING, LOTS 8B & 8C, BRENTWOOD CROSSING REPLAT NO.1, LOTS 8A1, 8A2, 8A3 & 8A4, BRENTWOOD CROSSING REPLAT NO. 2, AND PORTIONS OF TAX LOT 12, 14-14-12, TO BE REPLATTED AS LOTS 1 THRU 17 AND OUTLOTS A THRU C, LA VISTA CITY CENTRE, A SUBDIVISION LOCATED IN THE SOUTHWEST QUARTER OF SECTION 14, TOWNSHIP 14 NORTH, RANGE 12 EAST OF THE 6TH P.M., IN SARPY COUNTY, NEBRASKA.

WHEREAS, the applicant, La Vista City Centre LLC, on behalf of the owners of the above described piece of property, have made application for approval of a preliminary plat for Lots 1 thru 7, Brentwood Crossing, Lots 8B and 8C, Brentwood Crossing Replat No. 1, Lots 8A1, 8A2, 8A3 and 8A4, Brentwood Crossing Replat No. 2, and portions of Tax Lot 12, 14-14-12; and

WHEREAS, the City Engineer has reviewed the preliminary plat; and

WHEREAS, on June 2, 2016, the La Vista Planning Commission reviewed the preliminary plat and recommended approval subject to the following conditions:

1. Approval of the waiver of Section 4.24 of the Subdivision Regulations.

NOW THEREFORE, BE IT RESOLVED by the Mayor and City Council of the City of La Vista, Nebraska, that the preliminary plat for Lots 1 thru 7, Brentwood Crossing, Lots 8B & 8C, Brentwood Crossing Replat No. 1, Lots 8A1, 8A2, 8A3 and 8A4, Brentwood Crossing Replat No. 2, and portions of Tax Lot 12, 14-14-12, to be replatted as Lots 1 thru 17 and Outlots A thru C, La Vista City Centre, a subdivision located in the southwest quarter of Section 14, Township 14 North, Range 12 East of the 6th P.M., Sarpy County, Nebraska, generally located southeast of 84th Street and Summer Drive, be, and hereby is, approved.

BE IT FURTHER RESOLVED that a waiver of Section 4.24 of the Subdivision Regulations, regarding the minimum centerline radius of a local street, be granted.

PASSED AND APPROVED THIS 19TH DAY OF JULY, 2016.

CITY OF LA VISTA

ATTEST:

Douglas Kindig, Mayor

Pamela A. Buethe, CMC
City Clerk

RESOLUTION NO. _____

A RESOLUTION OF THE MAYOR AND CITY COUNCIL OF THE CITY OF LA VISTA, NEBRASKA, FOR APPROVAL OF THE PRELIMINARY PLAT FOR LOTS 1 THRU 7, BRENTWOOD CROSSING, LOTS 8B & 8C, BRENTWOOD CROSSING REPLAT NO.1, LOTS 8A1, 8A3 & 8A4, BRENTWOOD CROSSING REPLAT NO. 2, AND PORTIONS OF TAX LOT 12, 14-12-12, TO BE REPLATTED AS LOTS 1 THRU 17 AND OUTLOTS A THRU C, LA VISTA CITY CENTRE, A SUBDIVISION LOCATED IN THE SOUTHWEST QUARTER OF SECTION 14, TOWNSHIP 15 NORTH, RANGE 12 EAST OF THE 6TH P.M., IN SARPY COUNTY, NEBRASKA.

WHEREAS, the applicant, La Vista City Centre LLC, on behalf of the owners of the above described piece of property, have made application for approval of a preliminary plat for Lots 1 thru 7, Brentwood Crossing, Lots 8B and 8C, Brentwood Crossing Replat No. 1, Lots 8A1, 8A2, 8A3 and 8A4, Brentwood Crossing Replat No. 2, and portions of Tax Lot 12, 14-12-12; and

WHEREAS, the City Engineer has reviewed the preliminary plat; and

WHEREAS, on June 2, 2016, the La Vista Planning Commission reviewed the preliminary plat and recommended approval subject to the following conditions:

1. Approval of the waiver of Section 4.24 of the Subdivision Regulations.

NOW THEREFORE, BE IT RESOLVED by the Mayor and City Council of the City of La Vista, Nebraska, that the preliminary plat for Lots 1 thru 7, Brentwood Crossing, Lots 8B & 8C, Brentwood Crossing Replat No. 1, Lots 8A1, 8A2, 8A3 and 8A4, Brentwood Crossing Replat No. 2, and portions of Tax Lot 12, 14-12-12, to be replatted as Lots 1 thru 17 and Outlots A thru C, La Vista City Centre, a subdivision located in the southwest quarter of Section 14, Township 15 North, Range 12 East of the 6th P.M., Sarpy County, Nebraska, generally located southeast of 84th Street and Summer Drive, be, and hereby is, approved.

BE IT FURTHER RESOLVED that a waiver of Section 4.24 of the Subdivision Regulations, regarding the minimum centerline radius of a local street, be granted.

PASSED AND APPROVED THIS 19TH DAY OF JULY, 2016.

CITY OF LA VISTA

ATTEST:

Douglas Kindig, Mayor

Pamela A. Buethe, CMC
City Clerk



CITY OF LA VISTA
PLANNING DIVISION

RECOMMENDATION REPORT

CASE NUMBER: 2016-SUB-04

FOR HEARING OF: July 19, 2016
Report Prepared on: July 12, 2016

I. **GENERAL INFORMATION**

A. **APPLICANT:**

La Vista City Centre LLC
P.O. Box 428
Boys Town, NE 68010

B. **PROPERTY OWNERS:**

Lots 2-7 Brentwood Crossing, 8A1, 8A3 Brentwood Crossing
Replat No 2:

Brentwood Crossing Associates
211 North Stadium Blvd, Ste 201
Columbia, MO 65203

Lot 1 Brentwood Crossing:
Brentwood Crossing Associates II
211 North Stadium Blvd, Ste 201
Columbia, MO 65203

Lots 8B and 8C Brentwood Crossing Replat No 1; Lots 8A2, 8A4
Brentwood Crossing Replat No 2:
Brentwood Crossing Associates III
211 North Stadium Blvd, Ste 201
Columbia, MO 65203

Portions of Tax Lot 12 14-14-12:
City of La Vista
8116 Park View Blvd.
La Vista, NE 68128

C. **LOCATION:** Southeast of the intersection of 84th Street and Summer Drive.

D. **LEGAL DESCRIPTION:** Lots 1-7 Brentwood Crossing, Lots 8B, and 8C Brentwood Crossing Replat No 1, Lots 8A1, 8A2, 8A3, and 8A4 Brentwood Crossing Replat No 2, and portions of Tax Lot 12 14-14-12

E. **REQUESTED ACTION(S):** Preliminary plat for proposed Lots 1-17 and Outlots A-C of La Vista City Centre, and waiver of Section 4.24 of the Subdivision Regulations regarding the minimum centerline radius of a local street.

F. EXISTING ZONING AND LAND USE:
C-1 Shopping Center Commercial with a Gateway Corridor Overlay (Overlay District); various commercial uses. (proposed to be rezoned to MU-CC, Mixed Use City Centre District).

G. PURPOSE OF REQUEST:

1. Replat 13 lots listed in the request into 17 lots and 3 outlots for the purpose of redevelopment.
2. Waiver of Section 4.24 of the Subdivision Regulations regarding minimum centerline radius of a local street, from 200 feet to 100 feet.

H. SIZE OF SITE: 34.93 Acres

II. BACKGROUND INFORMATION

A. EXISTING CONDITION OF SITE: The property is the former site of the Brentwood Crossing shopping center. Most of the buildings are vacant. The main strip building and much of the parking is in poor condition. The land is generally flat with a gradual downward slope generally east and west of the high point of the Brentwood Drive entrance.

B. GENERAL NEIGHBORHOOD/AREA ZONING AND LAND USES:

1. **North:** La Vista Fall Golf Course, R-1 Single-Family Residential with a Gateway Corridor Overlay (Overlay District); Public Golf Course
2. **East:** Briarwood Subdivision and La Vista Junior High; R-1 Single-Family Residential; Single-Family Dwellings and Public School
3. **South:** Witham Place; C-1 Shopping Center Commercial District with a Gateway Corridor Overlay (Overlay District); Various Commercial uses.
4. **West:** Brentwood Square and Brentwood Plaza; C-1 Shopping Center Commercial District with a Gateway Corridor Overlay (Overlay District); Various Commercial uses.

C. RELEVANT CASE HISTORY:

1. N/A

D. APPLICABLE REGULATIONS:

1. Section 5.19 of the Zoning Regulations – MU-CC Mixed Use City Centre District
2. Section 3.03 of the Subdivision Regulations – Preliminary Plats

III. ANALYSIS

A. COMPREHENSIVE PLAN: The Future Land Use Map of the Comprehensive Plan designates the area for commercial uses.

B. OTHER PLANS: This site was identified in *A Vision Plan for 84th Street* as a mixed use city center. This site has also been designated as blighted and substandard and in need of redevelopment, and identified as the initial redevelopment project in the *84th Street Redevelopment Plan*.

C. TRAFFIC AND ACCESS:

1. Existing access points are at 84th Street and Summer Drive, 84th Street and Brentwood Drive, and 83rd Avenue. The preliminary plat proposes to move the intersection of 84th Street and Summer Drive approximately 275 feet south of its current location. This plat also proposes a new right-in/right-out between the relocated intersection and Brentwood Drive. A total of four vehicular access points will be available, including the private 83rd Avenue.

All existing sidewalk connections will remain. Additional sidewalk connections into the proposed park and to Marisu Lane are proposed.

2. As 84th Street is a state highway each new access point along the street needs approval from the Nebraska Department of Roads. The applicant has submitted a copy of their draft plan set to NDOR and has received approval for the access points along the western edge of the development. A copy of this letter, dated May 3, 2016 has been attached for review.
3. The City Engineer has reviewed a traffic study that was performed by Olsson Associates for the applicant. This study was also reviewed by the NDOR. The traffic study indicates that the additional right-in/right-out access point and the relocation of Summer Drive will not significantly affect traffic operations for through movements on 84th Street. The NDOR has indicated that with increased development and traffic growth, signal timings on 84th Street will be adjusted to maintain acceptable conditions on 84th Street during peak hours, but there may be delays on the side streets trying to enter onto 84th Street. This is not unusual as there is emphasis on keeping State Highways at a higher level of service than local streets. The study has identified that the intersection of 84th and Harrison is expected to experience high levels of delay in 2040. This is not the result of the City Centre project, although it is a contributor. The solutions identified in the report are to add additional through lanes on either Harrison Street or 84th Street, however, that is not the responsibility of this project and may not be feasible given right of way constraints.

D. UTILITIES:

1. The properties have access to water, sanitary sewer, gas, power and communication utilities.

IV. REVIEW COMMENTS:

1. The land swap areas identified on the preliminary plat will need to become part of the adjacent proposed Lots 11, 12, and 14. There will need to be an exchange of deeds as part of the subdivision or redevelopment agreements and that process would need to be completed prior to the final plat being recorded. The land swap areas should not be identified as individual lots.
2. The proposed west right-of-way line for 83rd Avenue adjacent to proposed Lots 1 and 2 will need to be at least 5 feet back of the proposed curb line to allow for traffic control signage and street lighting installation.
3. Itemized cost estimates for infrastructure improvements need to be provided per Article 3.03.15 of the Subdivision Regulations.
4. The typical sections on Sheet C3.1 indicate pavement thickness of 7 inches. Section 4.24 of the Subdivision Regulations indicates minimum pavement thicknesses. The footnotes to the table in that section indicate a minimum of 8 inches for streets in commercially zoned areas. There should be a discussion with the applicant as to whether the drive aisles could be 8 inches thick and the parking stalls could be 6 inches thick. If the streets remain at 7-inches thick, then a waiver request should be processed.
5. A revised conceptual Post Construction Storm Water Management plan for addressing water quality was submitted. There needs to be a discussion with the School District to explore shared storm water management facilities as well as other aspects such as grading and future street patterns. This meeting needs to occur before design of infrastructure proceeds and the City should arrange the meeting.
6. The applicant has submitted a request to waive Section 4.24 of the Subdivision Regulations to reduce the minimum horizontal centerline radii for local streets from 200 feet to 100 feet. This waiver request was submitted through their response letter received by the City on April 26, 2016. A copy of this letter has been attached for review.

V. STAFF RECOMMENDATION – Waiver of Section 4.24 of the Subdivision Regulations:

Approval of the request for waiver of Section 4.24 of the Subdivision Regulations as flexibility in the horizontal centerline radii is needed to meet the design for a city center district portrayed within the Vision 84 plan.

VI. PLANNING COMMISSION RECOMMENDATION – Waiver of Section 4.24 of the Subdivision Regulations:

The Planning Commission met on June 2, 2016 and unanimously recommended approval of the request for waiver of Section 4.24 of the Subdivision Regulations as flexibility in the horizontal centerline radii is needed to meet the design for a City Center district portrayed within the Vision 84 plan.

VII. STAFF RECOMMENDATION – Preliminary Plat:

Approval of La Vista City Centre Preliminary Plat, contingent upon approval of the waiver request, as the Preliminary Plat request is consistent with the Comprehensive Plan and the Subdivision Regulations.

VIII. PLANNING COMMISSION RECOMMENDATION – Preliminary Plat:

The Planning Commission met on June 2, 2016 and unanimously recommended approval of the La Vista City Centre Preliminary Plat, contingent upon approval of the waiver request, as the Preliminary Plat request is consistent with the Comprehensive Plan and the Subdivision Regulations.

IX. ATTACHMENTS TO REPORT:

1. Vicinity Map
2. Staff Review Letters and Applicant Response Letter
3. NDOR Access Control Revision Letter
4. Waiver Request Letter
5. Preliminary Plat Map

X. COPIES OF REPORT SENT TO:

1. Eric Galley, Olsson Associates Inc.
2. Chris Erickson, La Vista City Centre, LLC
3. Public Upon Request

Prepared by: _____

 _____ 7-17-16
Community Development Director Date

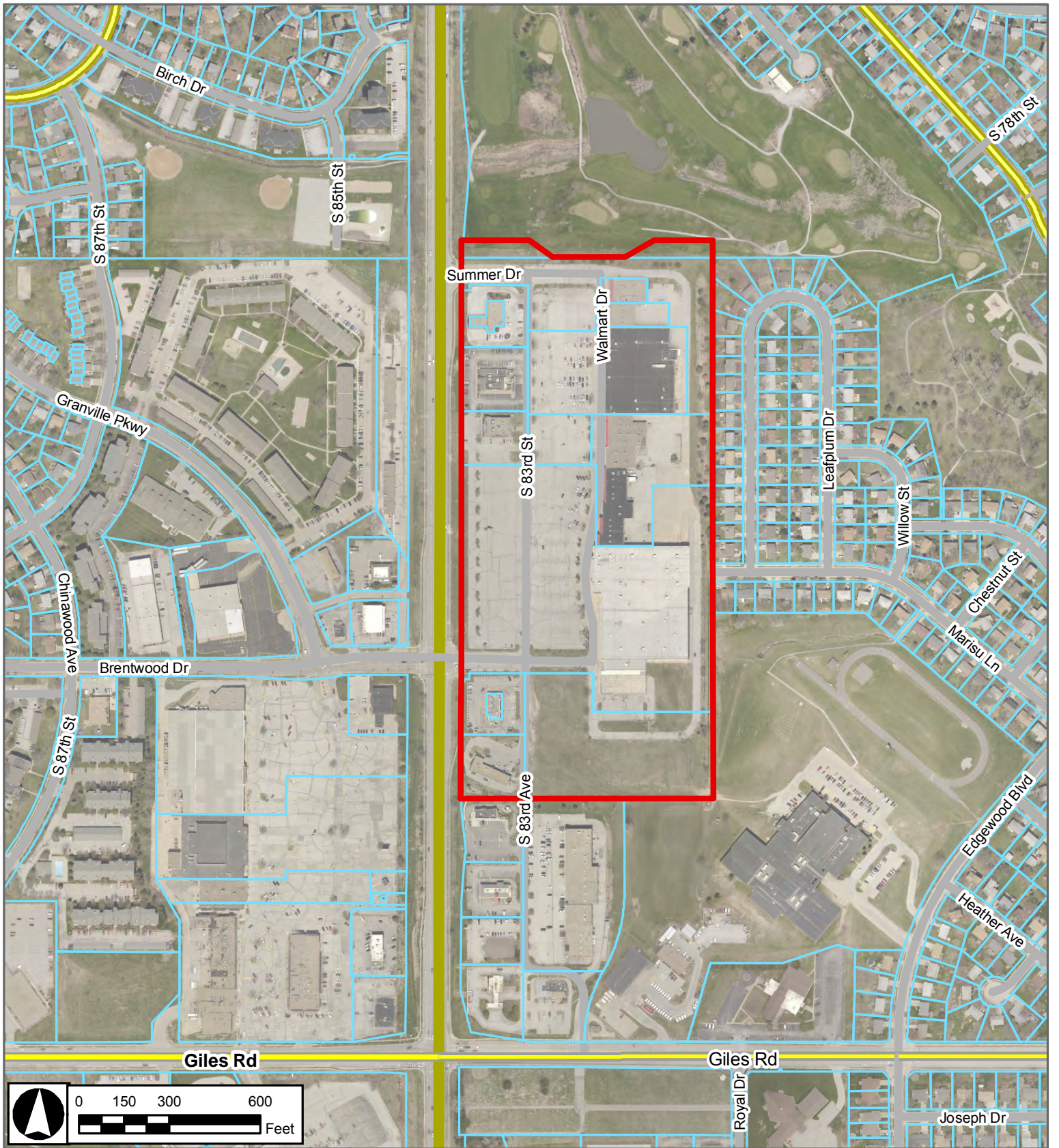

Project Vicinity Map

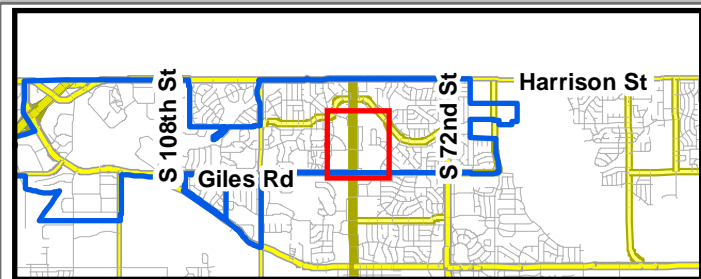

**Preliminary Plat
La Vista City Centre**

05-27-2016
CAS





April 18, 2016

Eric Galley
Olsson Associates
2111 S 67th Street, Suite 200
Omaha, NE 68106

RE: Preliminary Plat – Initial Review
La Vista City Centre

Mr. Galley,

We have reviewed the documents submitted for the above-referenced application. Based on the elements for consideration set forth in the applicable section of the Subdivision Regulations for the Preliminary Plat the City has the following comments:

1. Phase II of the proposed plat needs to be delineated as an out lot and left blank, allowing for review of the proposed site design at the time of development of that phase.
2. On Sheet C3.2 there needs to be a note added stating that a single grading and erosion control permit will be obtained for all lots in the preliminary plat. The fewest number of grading permits is preferred to allow for ease of administration and coordination of inspections as well as reducing permit costs for the applicant.
3. The existing topographic contours, utilizing currently available GIS data, for the adjoining developments to the east and to the south of the proposed plat need to be delineated on the map.
4. The existing easements on the property need to be illustrated on Sheet C1.1. This is needed in order to determine what releases and/or relocation of easements are required. This is particularly important with easements connected to Wiltham Place to the south. There is also an existing public sidewalk easement along the south side of the property.
5. The proposed “land swap” on Sheet C1.1 needs clarification as to what is being swapped for the shaded area. This might be clarified in a draft subdivision agreement if illustration on the plans is not practical. At a minimum, the acreage of the areas needs to be delineated on the map.

City Hall
8116 Park View Blvd.
La Vista, NE 68128-2198
p: 402-331-4343
f: 402-331-4375

Community Development
8116 Park View Blvd.
p: 402-331-4343
f: 402-331-4375

Fire
8110 Park View Blvd.
p: 402-331-4748
f: 402-331-0410

Golf Course
8305 Park View Blvd.
p: 402-339-9147

Library
9110 Giles Rd.
p: 402-537-3900
f: 402-537-3902

Police
7701 South 96th St.
p: 402-331-1582
f: 402-331-7210

Public Buildings & Grounds
8112 Park View Blvd.
p: 402-331-4343
f: 402-331-4375

Public Works
9900 Portal Rd.
p: 402-331-8927
f: 402-331-1051

Recreation
8116 Park View Blvd.
p: 402-331-3455
f: 402-331-0299

www.cityoflavista.org
info@cityoflavista.org

6. To satisfy Article 3.03.06 of the Subdivision Regulations the legal description of the property as currently platted needs to be set forth on Sheet C1.1 with a statement of the total acreage involved in the proposed platting. This would include the proposed portions of the golf course property to be incorporated into the project.
7. A preliminary traffic impact analysis has been submitted which is currently under review by the NDOR to support the proposed relocation of Summer Drive to the south and the proposed additional right-in/right-out access break between Brentwood Drive and Summer Drive. The preliminary study identifies concerns with the intersection of 84th and Harrison Streets and does not address the future west leg of Summer Drive. The City Engineer recommends that the traffic study be discussed in a meeting with the consultants for these two topics and any comments that come back from the NDOR.
8. There is an existing sanitary sewer that connects to Wiltham Place in the existing sewer easement shown on C2.1. The proposed utility plan on Sheet C3.1 will need to provide for reconnecting that sewer and relocating as appropriate.
9. The centerline radii of proposed public streets need to be identified on Sheet C1.1. These radii need to comply with the Nebraska Board of Public Roads Classifications and Standards as well as the Subdivision Regulations, Section 4.24. The Board of Public Roads Classifications and Standards allows for local streets to have minimum horizontal centerline radii of 100 feet if the roads will have a design speed of 30 mph or less. However, Section 4.24 of the Subdivision Regulations requires 200 feet radii for local streets and 100 feet radii for cul-de-sac streets. The City Engineer recommends a minimum of 100 feet centerline radii. A waiver for local streets minimum centerline radii will be needed if the proposal is less than 200 feet.
10. The proposed right of way for 83rd Avenue adjacent to proposed Lots 1 and 2 (Brentwood Car Wash and McDonalds) needs to be revised as it lies within the existing parking lot of these facilities.
11. The existing sidewalk from 83rd Avenue heading east towards the school needs to be shown. In general, sidewalk connections within the development and to external connections will need to be reviewed to ensure a safe and inviting environment for pedestrians. Sidewalk connections will be reviewed in detail at the time of site plan review for each lot.
12. Proposed easements for utilities need to be shown per Article 3.03.12. For example, there are proposed water mains crossing Outlots A, B and C. Will there be blanket easements over these outlots? Also, there is a note on Sheet C1.1 that "standard utility dedications" will be provided on the final plat. Staff

doesn't consider this to be appropriate as there are likely to be many instances with zero building setbacks so that standard easement dedications will be in conflict.

13. The existing zoning is listed on Sheet C1.1 as C-1 Shopping Center District. Please revise to include the Gateway Corridor Overlay District. Also please revise the Existing Zoning Map to depict the Gateway Corridor Overlay District as well. Future zoning will have the MU-CC district as shown, without the Gateway Corridor district.
14. Article 3.03.15 requires a draft subdivision agreement with itemized cost estimates for infrastructure improvements that allocate funding sources. Staff's understanding is that such an agreement is in progress between the Developer and the City Attorney.
15. The proposed pavement type and thickness needs to be noted on Sheet C3.1 in the typical sections. This is needed per Article 3.03.20(3) of the Subdivision Regulations.
16. There needs to be submittal of a draft Post Construction Storm Water Management Maintenance & Easement Agreement. The associated storm water management plan needs to provide a conceptual plan for addressing water quality for the first one-half inch of runoff and to maintain 2-year storm event post-development flows equal to, or less than, pre-development flows. On Sheet C3.2 please identify the proposed drainage boundary between the portion of the site that will drain to the north (to the golf course) and the portion that will drain to the east (into the school property). These requests are made per Article 3.03.20(4) of the Subdivision Regulations.
17. The cul-de-sac proposed in the east end of Summer Drive should be moved closer to the end of that road and the entrance to the parking structure to allow for plowing operations to turn-around closer to the end of the street.
18. Note 1 on Sheet C3.1 indicates gas to be provided by MUD. Gas will be provided by Black Hills Energy.
19. The existing Chili's configuration on proposed Lot 7 should be shown as we understand that facility is to remain in its current configuration. The manner in which that will be incorporated into the project should be shown.
20. Access and utilities will have to be maintained to the existing Brentwood Car Wash and McDonalds. There are some notations, such as construction entrances, that conflict with the need to do such.

Further review will be needed when cost estimates and water quality proposals have been submitted along with revised materials addressing these comments and review comments from others.

The initial submittal will be routed out to secondary reviewers for their comment period on April 20, 2016. Any comments from secondary reviewers will need to be addressed prior to the submission of exhibits for Planning Commission packets.

In order for the Preliminary Plat to be considered for review at the May 19, 2016 Planning Commission meeting, revised plat documents will need to be provided for further review. Please submit 4 full size copies (along with electronic copies) of the revised documents by April 25, 2016 to ensure that the application stays on track for the review by Planning Commission.

If you have any questions regarding these comments please feel free to contact me at any time.

Thank you,



Christopher Solberg, AICP
City Planner

cc: Ann Birch, Community Development Director
John Kottmann, City Engineer
Chris Erickson, La Vista City Centre LLC

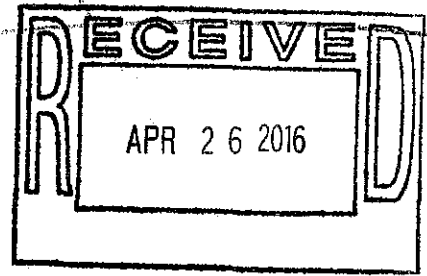

April 25, 2016

Christopher Solberg
City of La Vista
8116 Park View Blvd
LaVista, NE 68128

Re: Preliminary Plat – Initial Review La Vista City Centre

Dear Mr. Solberg,

Please find enclosed a resubmittal of the Preliminary Plat which incorporates the revisions requested through the Staff Report dated April 18, 2016.

Submittal documents are as follows:

- o Revised Preliminary Plat Plans (4 copies)

Below you will find comment responses to the staff report.

1. Phase II of the proposed plat needs to be delineated as an out lot and left blank, allowing for review of the proposed site design at the time of development of that phase.

Response: Phase II is now shown as an outlot

2. On Sheet C3.2 there needs to be a note added stating that a single grading and erosion control permit will be obtained for all lots in the preliminary plat. The fewest number of grading permits is preferred to allow for ease of administration and coordination of inspections as well as reducing permit costs for the applicant.

Response: Note has been added to the plan

3. The existing topographic contours, utilizing currently available GIS data, for the adjoining developments to the east and to the south of the proposed plat need to be delineated on the map.

Response: Existing topographic contours are now shown

4. The existing easements on the property need to be illustrated on Sheet C1.1. This is needed in order to determine what releases and/or relocation of easements are required. This is particularly important with easements connected to Wiltham Place to the south. There is also an existing public sidewalk easement along the south side of the property.

Response: Existing easements are now shown

5. The proposed "land swap" on Sheet C1.1 needs clarification as to what is being swapped for the shaded area. This might be clarified in a draft subdivision agreement if illustration on the plans is not practical. At a minimum, the acreage of the areas needs to be delineated on the map.

Response: Acreages have been added to the plat. The specifics of the swap are planned to be clarified in the subdivision agreement.

6. To satisfy Article 3.03.06 of the Subdivision Regulations the legal description of the property as currently platted needs to be set forth on Sheet C1.1 with a statement of the total acreage involved in the proposed platting. This would include the proposed portions of the golf course property to be incorporated into the project.

Response: A legal description has been added

7. A preliminary traffic impact analysis has been submitted which is currently under review by the NDOR to support the proposed relocation of Summer Drive to the south and the proposed additional right-in/right-out access break between Brentwood Drive and Summer Drive. The preliminary study identifies concerns with the intersection of 84th and Harrison Streets and does not address the future west leg of Summer Drive. The City Engineer recommends that the traffic study be discussed in a meeting with the consultants for these two topics and any comments that come back from the NDOR.

Response: Upon receipt of NDOR's comments the Developer would agree that further discussion with the City be had to address the traffic related details.

8. There is an existing sanitary sewer that connects to Wiltham Place in the existing sewer easement shown on C2.1. The proposed utility plan on Sheet C3.1 will need to provide for reconnecting that sewer and relocating as appropriate.

Response: Sewer service will be provided to Wiltham Place

9. The centerline radii of proposed public streets need to be identified on Sheet C1.1. These radii need to comply with the Nebraska Board of Public Roads Classifications and Standards as well as the Subdivision Regulations, Section 4.24. The Board of Public Roads Classifications and Standards allows for local streets to have minimum horizontal centerline radii of 100 feet if the roads will have a design speed of 30 mph or less. However, Section 4.24 of the Subdivision Regulations requires 200 foot radii for local streets and 100 foot radii for cul-de-sac streets. The City Engineer recommends a minimum of 100 foot centerline radii. A waiver for local streets minimum centerline radii will be needed if the proposal is less than 200 feet.

Response: All centerline radii have been updated to 100'. A waiver for the reduction in centerline radii from 200' to 100' is attached to this resubmittal.

10. The proposed right of way for 83rd Avenue adjacent to proposed Lots 1 and 2 (Brentwood Car Wash and McDonalds) needs to be revised as it lies within the existing parking lot of these facilities.

Response: The proposed Right of Way for 83rd Ave has been adjusted

11. The existing sidewalk from 83rd Avenue heading east towards the school needs to be shown. In general, sidewalk connections within the development and to external connections will need to be reviewed to ensure a safe and inviting environment for pedestrians. Sidewalk connections will be reviewed in detail at the time of site plan review for each lot.

Response: The existing sidewalk is shown

12. Proposed easements for utilities need to be shown per Article 3.03.12. For example, there are proposed water mains crossing Outlots A, B and C. Will there be blanket easements over these outlots? Also, there is a note on Sheet C1.1 that "standard utility dedications" will be provided on the final plat. Staff doesn't consider this to be appropriate as there are likely to be many instances with zero building setbacks so that standard easement dedications will be in conflict.

Response: The utilities have been routed around the proposed Outlots. In addition the note referring to standard utility dedications has been removed.

13. The existing zoning is listed on Sheet C1.1 as C-1 Shopping Center District. Please revise to include the Gateway Corridor Overlay District. Also please revise the Existing Zoning Map to depict the Gateway Corridor Overlay District as well. Future zoning will have the MU-CC district as shown, without the Gateway Corridor district.

Response: This has been noted on the plat

14. Article 3.03.15 requires a draft subdivision agreement with itemized cost estimates for infrastructure improvements that allocate funding sources. Staff's understanding is that such an agreement is in progress between the Developer and the City Attorney.

Response: Draft subdivision agreement is in progress between developer and City Attorney. Infrastructure cost estimate will accompany the draft subdivision agreement.

15. The proposed pavement type and thickness needs to be noted on Sheet C3.1 in the typical sections. This is needed per Article 3.03.20(3) of the Subdivision Regulations.

Response: Proposed pavement thicknesses have been noted per the City's subdivision regulations.

16. There needs to be submittal of a draft Post Construction Storm Water Management Maintenance & Easement Agreement. The associated storm water management plan needs to provide a conceptual plan for addressing water quality for the first one-half inch of runoff and to maintain 2-year storm event post-development flows equal to, or less than, pre-development flows. On Sheet C3.2 please identify the proposed drainage boundary between the portion of the site that will drain to the north (to the golf course) and the portion that will drain to the east (into the school property). These requests are made per Article 3.03.20(4) of the Subdivision Regulations.

Response: The draft Post Construction Storm Water Management Maintenance & Easement Agreement has been submitted to the City for review.

17. The cul-de-sac proposed in the east end of Summer Drive should be moved closer to the end of that road and the entrance to the parking structure to allow for plowing operations to turn-around closer to the end of the street.

Response: The cul-de-sac has been updated

18. Note 1 on Sheet C3.1 indicates gas to be provided by MUD. Gas will be provided by Black Hills Energy.

Response: The note has been updated

19. The existing Chili's configuration on proposed Lot 7 should be shown as we understand that facility is to remain in its current configuration. The manner in which that will be incorporated into the project should be shown.

Response: The existing Chili's building is now shown

20. Access and utilities will have to be maintained to the existing Brentwood Car Wash and McDonalds. There are some notations, such as construction entrances, that conflict with the need to do such.

Response: Access and utilities to the existing Brentwood Car Wash and McDonalds will be maintained throughout construction

Thank you for your consideration. If you have any questions, please contact me at 402-341-1116.

Sincerely,

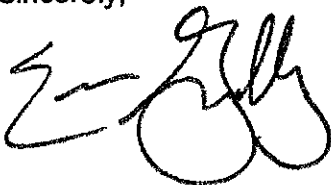

Eric Galley, PE



May 17, 2016

Eric Galley
Olsson Associates
2111 S 67th Street, Suite 200
Omaha, NE 68106

RE: Preliminary Plat – 2nd Review
La Vista City Centre

Mr. Galley,

We have reviewed the revised documents submitted for the above-referenced application. Based on the elements for consideration set forth in the applicable section of the Subdivision Regulations for the Preliminary Plat the City has the following comments:

1. The land swap areas identified on the preliminary plat will need to become part of the adjacent proposed Lots 11, 12, and 14. There will need to be an exchange of deeds as part of the subdivision or redevelopment agreements and that process would need to be completed prior to the final plat being recorded. The swap areas should not be identified as individual lots.
2. The proposed west right-of-way line for 83rd Avenue adjacent to proposed Lots 1 and 2 will need to be at least 5 feet back of the proposed curb line to allow for traffic control signage and street lighting installation.
3. Itemized cost estimates for infrastructure improvements need to be provided per Article 3.03.15 of the Subdivision Regulations.
4. The typical sections on Sheet C3.1 indicate pavement thickness of 7 inches. Section 4.24 of the Subdivision Regulations indicates minimum pavement thicknesses. The footnotes to the table in that section indicate a minimum of 8 inches for streets in commercially zoned areas. There should be a discussion with the applicant as to whether the drive aisles in the typical sections could be 8 inches thick and the parking stalls could be 6 inches thick. If the streets remain at 7-inches thick, then a waiver request should be processed.
5. A revised conceptual Post Construction Storm Water Management plan for addressing water quality was submitted. There needs to be a discussion with the School District to explore shared storm water management facilities as

City Hall
8116 Park View Blvd.
La Vista, NE 68128-2198
p: 402-331-4343
f: 402-331-4375

Community Development
8116 Park View Blvd.
p: 402-331-4343
f: 402-331-4375

Fire
8110 Park View Blvd.
p: 402-331-4748
f: 402-331-0410

Golf Course
8305 Park View Blvd.
p: 402-339-9147

Library
9110 Giles Rd.
p: 402-537-3900
f: 402-537-3902

Police
7701 South 96th St.
p: 402-331-1582
f: 402-331-7210

Public Buildings & Grounds
8112 Park View Blvd.
p: 402-331-4343
f: 402-331-4375

Public Works
9900 Portal Rd.
p: 402-331-8927
f: 402-331-1051

Recreation
8116 Park View Blvd.
p: 402-331-3455
f: 402-331-0299

www.cityoflavista.org
info@cityoflavista.org

well as other aspects such as grading and future street patterns. This meeting needs to occur before design of infrastructure proceeds and the City will arrange the meeting.

In order for the Preliminary Plat to be considered for review at the June 2, 2016 Planning Commission meeting, revised preliminary plat documents will need to be provided for the Planning Commission packets. Please submit 10 full-size and 4 ledger-size copies (along with electronic copies) of the revised documents by May 25, 2016 to ensure that the application stays on track for the review by Planning Commission.

If you have any questions regarding these comments please feel free to contact me at any time.

Thank you,

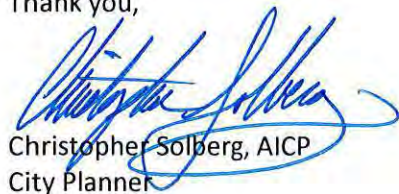
A handwritten signature in blue ink, appearing to read "Christopher Solberg", is written over the typed name and title.

Christopher Solberg, AICP
City Planner

cc: Ann Birch, Community Development Director
John Kottmann, City Engineer
Chris Erickson, La Vista City Centre LLC
File



May 25, 2016

Christopher Solberg
City of La Vista
8116 Park View Blvd
La Vista, NE 68128

Re: Preliminary Plat – 2nd Review La Vista City Centre

Dear Mr. Solberg,

Please find enclosed a resubmittal of the Preliminary Plat which incorporates the revisions requested through the Staff Report dated May 17, 2016.

Submittal documents are as follows:

- o Revised Preliminary Plat Plans (4 copies)

Below you will find comment responses to the staff report.

1. The land swap areas identified on the preliminary plat will need to become part of the adjacent proposed Lots 11, 12, and 14. There will need to be an exchange of deeds as part of the subdivision or redevelopment agreements and that process would need to be completed prior to the final plat being recorded. The swap areas should not be identified as individual lots.
Response: Former land swap areas have been incorporated into Lots 11, 12, and 14.
2. The proposed west right-of-way line for 83rd Avenue adjacent to proposed Lots 1 and 2 will need to be at least 5 feet back of the proposed curb line to allow for traffic control signage and street lighting installation.
Response: The right-of-way line has been adjusted.
3. Itemized cost estimates for infrastructure improvements need to be provided per Article 3.03.15 of the Subdivision Regulations.
Response: An Engineer's Opinion of Cost has been prepared and included.

4. The typical sections on Sheet C3.1 indicate pavement thickness of 7 inches. Section 4.24 of the Subdivision Regulations indicates minimum pavement thicknesses. The footnotes to the table in that section indicate a minimum of 8 inches for streets in commercially zoned areas. There should be a discussion with the applicant as to whether the drive aisles in the typical sections could be 8 inches thick and the parking stalls could be 6 inches thick. If the streets remain at 7-inches thick, then a waiver request should be processed.

Response: The typical section pavement thickness has been increased to 8 inches per the Subdivision Regulations and preliminary geotechnical report. Parking stall pavement thickness has been set at 5 inches per the preliminary geotechnical report.

5. A revised conceptual Post Construction Storm Water Management plan for addressing water quality was submitted. There needs to be a discussion with the School District to explore shared storm water management facilities as well as other aspects such as grading and future street patterns. This meeting needs to occur before design of infrastructure proceeds and the City will arrange the meeting.

Response: Olsson Associates will be involved in the coordination of the stormwater needs for the development.

Thank you for your consideration. If you have any questions, please contact me at 402-341-1116.

Sincerely,



Eric Galley, PE



Pete Ricketts
Governor

STATE OF NEBRASKA

DEPARTMENT OF ROADS

Kyle Schneeweis, P.E., Director

1500 Highway 2 • PO Box 94759 • Lincoln NE 68509-4759

Phone (402) 471-4567 • FAX (402) 479-4325 • www.roads.nebraska.gov

May 3, 2016

City of La Vista
9900 Portal Road
John Kottmann
LaVista, NE, 68128

RE: Proposed Access Control Revision on Highway 85

Dear Mr. Kottman :

The Nebraska Department of Roads (NDOR) has reviewed the City of LaVista's permit application and corresponding Traffic Impact Study for the Town Center development along highway N-85 (84th Street) between Brentwood Drive and Summer Drive. The two requests from the City were to relocate the existing Summer Drive approximately 250' south of the current location, as well as adding a new Right-In/Right-Out (RI/RO) drive approximately 515' north of the existing Brentwood Drive. This RI/RO location will serve the property on the east side of N-85 (84th Street). The new Summer Drive location will only serve the development on the east side of N-85 (84th Street); if the City chooses to connect to the west side of N-85 at Summer Drive in the future, a separate permit application will be required.

The state highway mainline progression during peak hours with modifications to the signal timings, will allow for overall acceptable results, but may result in greater delays on the minor approaches. The results of the study were discussed with the City. The upcoming "84th St ASCT, HSIP-5023(18), CN 22695" project will also benefit the highway travel times along this state highway corridor.

Based on our review, NDOR approves of the new access points as proposed by the City, with the understanding that NDOR will receive the final Traffic Impact Study with our comments addressed. Also NDOR should receive all recorded plats, plan details, geometrics, pavement type, erosion control and drainage, at the appropriate time for NDOR review and approval.

If you have any additional questions or need any additional information, please let me know at 402 479-4770.

Sincerely,

Todd Wicken
Property Management Supervisor
Cc: Tim Weander



Christopher Solberg
City of La Vista
8116 Park View Blvd
LaVista, NE 68128

Re: Preliminary Plat – Initial Review La Vista City Centre

Dear Mr. Solberg,

We are requesting the following waivers as they relate to the La Vista City Centre Subdivision generally located at 84th and Brentwood Dr.

Pursuant to Section 4.24 of the City of La Vista Subdivision Regulations, local roads shall have a centerline radius of no less than 200'. According to the Board of Public Roads Classifications and Standards the minimum horizontal centerline radii for a local road with a design speed of 30 mph or less is 100 feet.

The developer would like to request that all roads within the subdivision with a design speed of 30 mph or less be allowed a minimum centerline radius of 100 feet.

Thank you for your time and consideration. Please contact me with any questions at (402) 970-2319.

Sincerely,

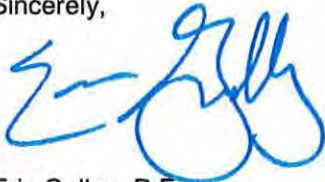
A handwritten signature in blue ink, appearing to read "Eric Galley".

Eric Galley, P.E.

DWG: F:\2016\0501-1000\016-0546\4d-design\AutoCAD\preliminary plans\Sheets\LDVPC_EXC_60546.dwg USER: pnievohner
 DATE: May 25, 2016 11:39am XREFS: C:\TBLK_60546 C:\XBASE_60546

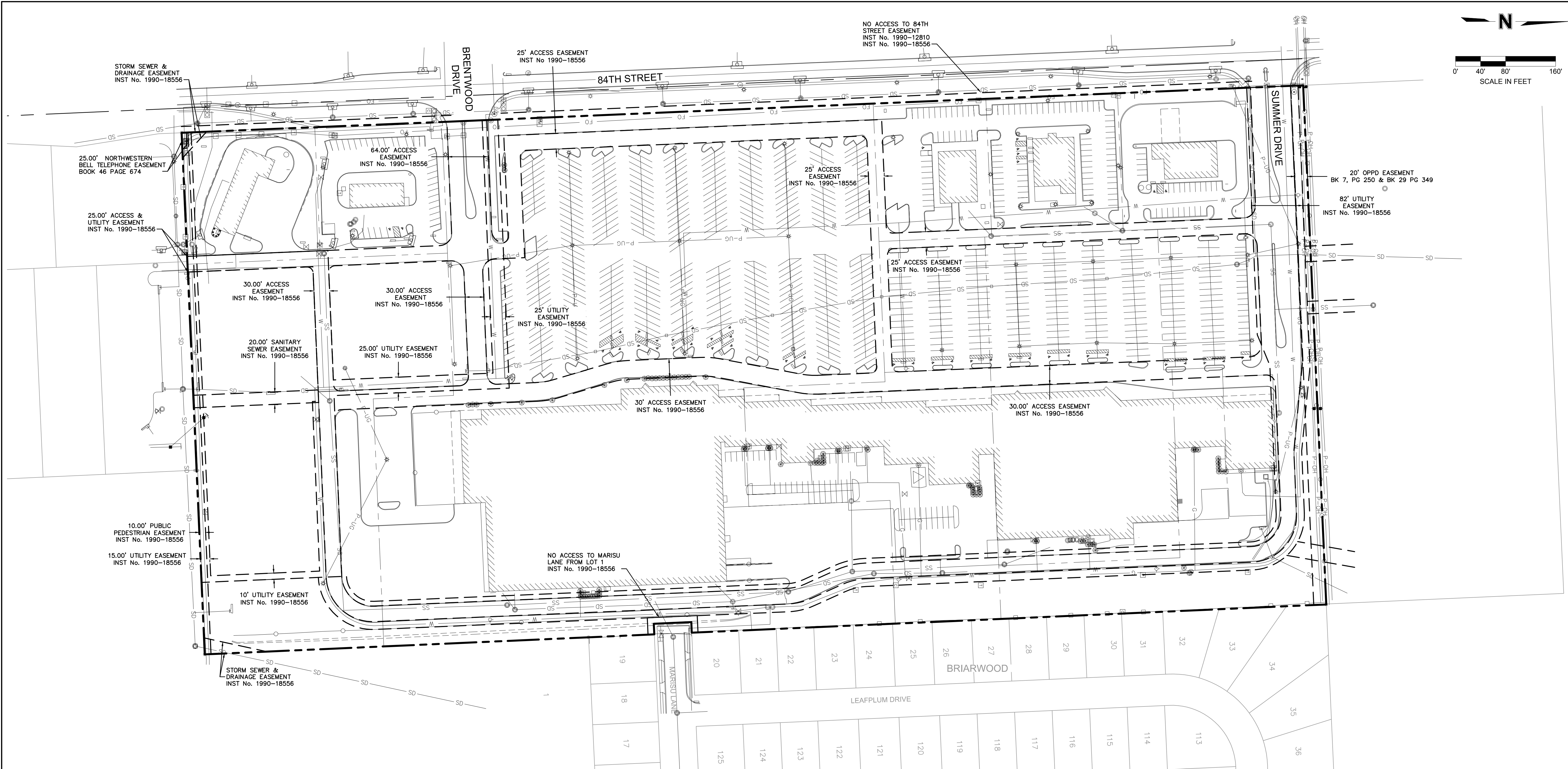

LEGEND

| | |
|------|-------------------------|
| ——— | BOUNDARY LINE |
| --- | SECTION LINE |
| --- | EXISTING PROPERTY LINE |
| --- | EXISTING EASEMENT LINE |
| SS | EXISTING SANITARY SEWER |
| P-OH | EXISTING OVERHEAD POWER |
| G | EXISTING GAS LINE |
| SD | EXISTING STORM SEWER |
| W | EXISTING WATER LINE |

| REV. NO. | DATE | REVISIONS DESCRIPTION |
|----------|------|-----------------------|
| | | |
| | | |
| | | |
| | | |
| | | |

EXISTING CONDITIONS PLAN
 LA VISTA CITY CENTRE
 84TH STREET AND BRENTWOOD DRIVE
 LA VISTA, NE

drawn by: CAS
 checked by: ERG
 approved by: ERG
 QA/QC by: ERG
 project no.: 016-0546
 drawing no.:
 date: 04.04.2016

DWG: F:\2016\0501-1000\016-0546\40-Design\AutoCAD\Pre\Site\LA_VISTA_SIT_60546.dwg USER: pnievehner
 DATE: May 25, 2016 11:41am XREFS: C:\BLK_60546 C:\PBASE_60546 C:\PNDY_60546 C:\PLI_60546 C:\PUTIL_60546 C:\PJT_60546

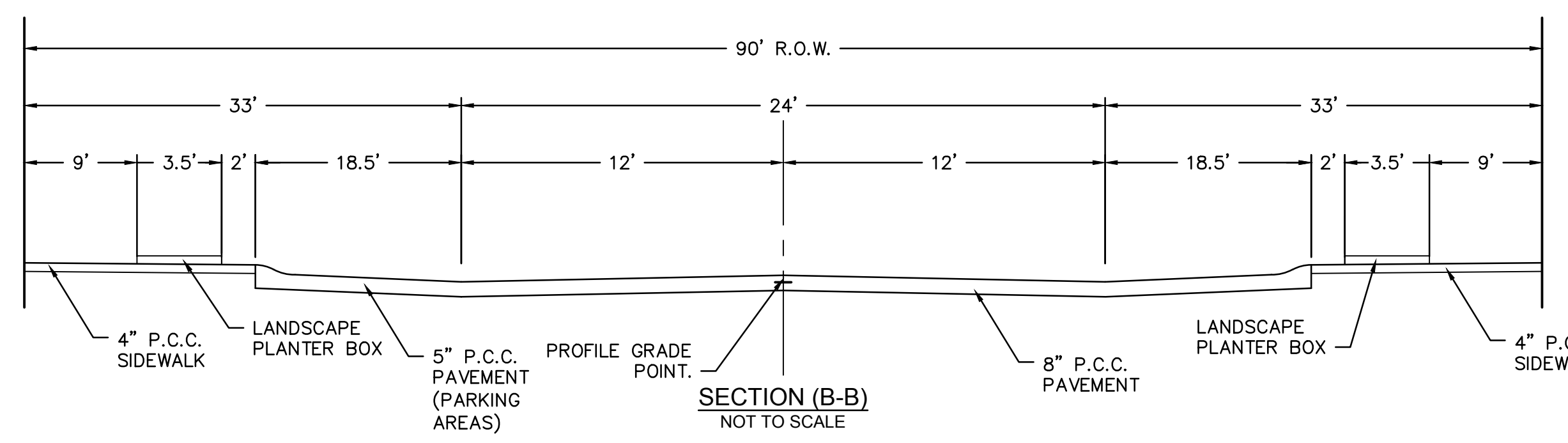
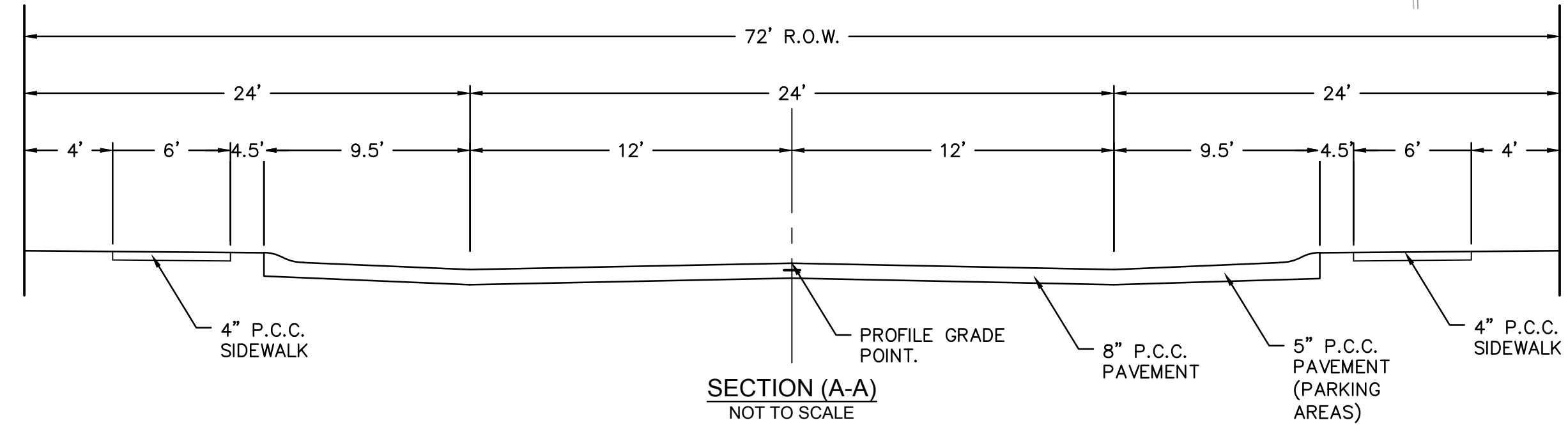
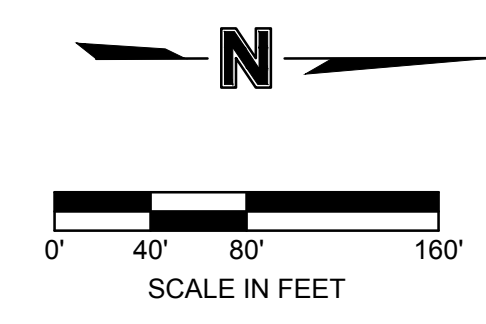
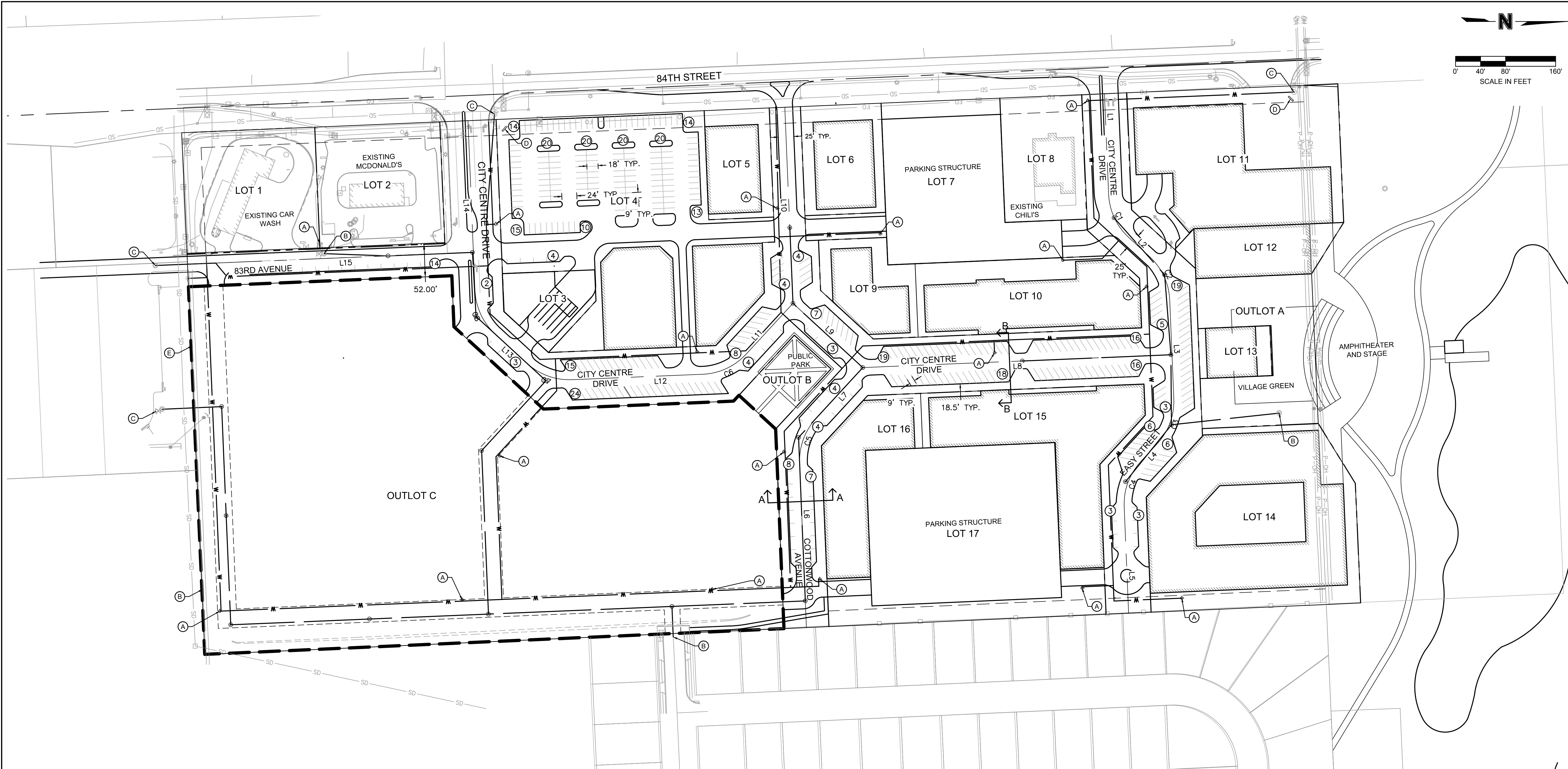

| KEY MAP | |
|---------|---------------------------------|
| (A) | FIRE HYDRANT |
| (B) | EXISTING SANITARY SEWER MANHOLE |
| (C) | CONNECT TO EXISTING WATER |
| (D) | MONUMENT SIGN |
| (E) | EXISTING SIDEWALK |

| LEGEND | |
|--------|-------------------------|
| --- | BOUNDARY LINE |
| --- | SECTION LINE |
| --- | EXISTING PROPERTY LINE |
| SS | EXISTING SANITARY SEWER |
| P-OH | EXISTING OVERHEAD POWER |
| G | EXISTING GAS LINE |
| SD | EXISTING STORM SEWER |
| W | EXISTING WATER LINE |
| --- | PROPOSED SANITARY SEWER |
| --- | PROPOSED WATER LINE |

- NOTES:**
1. WATER PROVIDED BY M.U.D. GAS TO BE PROVIDED BY BLACK HILLS ENERGY.
 2. POWER TO BE PROVIDED BY O.P.P.D.
 3. TELEPHONE AND CABLE TO BE PROVIDED BY LOCAL SERVICE.
 4. THE CALCULATION OF THE AREA REQUIRING CONTROL OF THE FIRST ONE HALF INCH OF RUNOFF SHALL BE BASED ONLY ON THE IMPERVIOUS AREA OF THE PROJECT BEING ADDED OR REPLACED.
 5. THE FINAL POST CONSTRUCTION STORMWATER MANAGEMENT PLAN SHALL BE SUBMITTED FOR APPROVAL AT THE TIME OF BUILDING PERMIT.
 6. ALL DIMENSIONS ARE TO BACK OF CURB, UNLESS OTHERWISE NOTED.

OLSSON ASSOCIATES

2111 South 67th Street, Suite 200
 Omaha, NE 68106
 TEL 402.341.1116
 FAX 402.341.5895
 www.olssonassociates.com

| REV. NO. | DATE | REVISIONS DESCRIPTION |
|----------|------|-----------------------|
| | | |
| | | |
| | | |

PRELIMINARY SITE AND UTILITY PLAN
 LA VISTA CITY CENTRE
 84TH STREET AND BRENTWOOD DRIVE

2016
 REVISIONS

LA VISTA, NE

SHEET
 C3.1

DWG: F:\2016\0501-1000\016-0546\4d-design\AutoCAD\Drawings\preliminary plans\Sheets\LD\VIC_RPP_60546.dwg
 DATE: May 25, 2016 11:43am XREFS: C:\BLK_60546 C:\PALGN_60546 USER: pnievothner

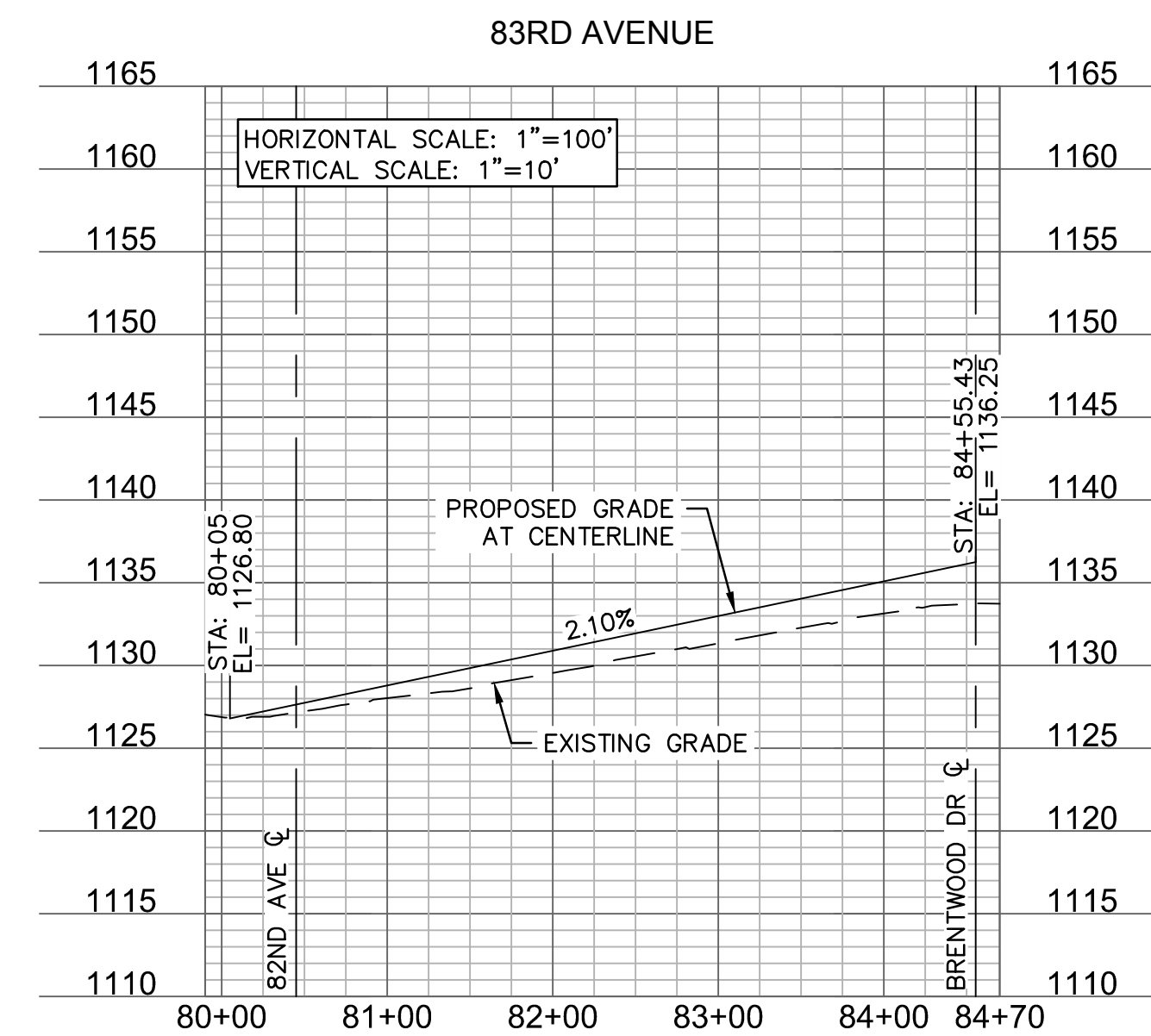
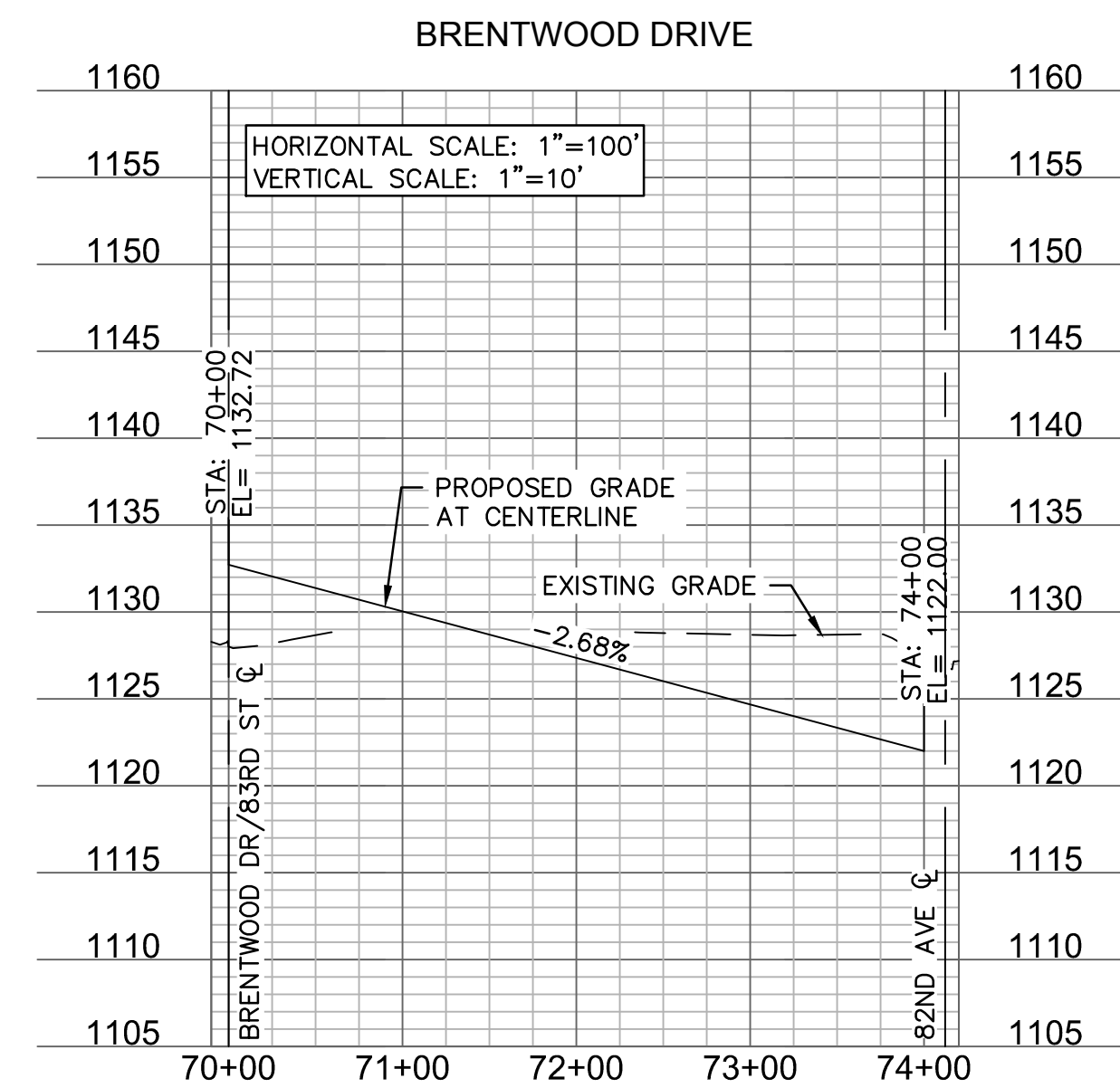
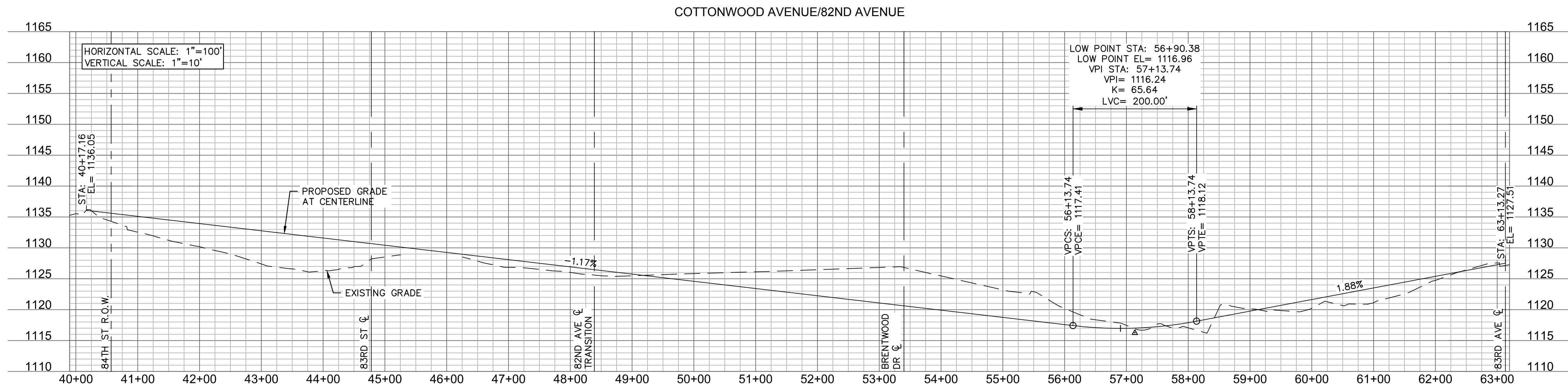
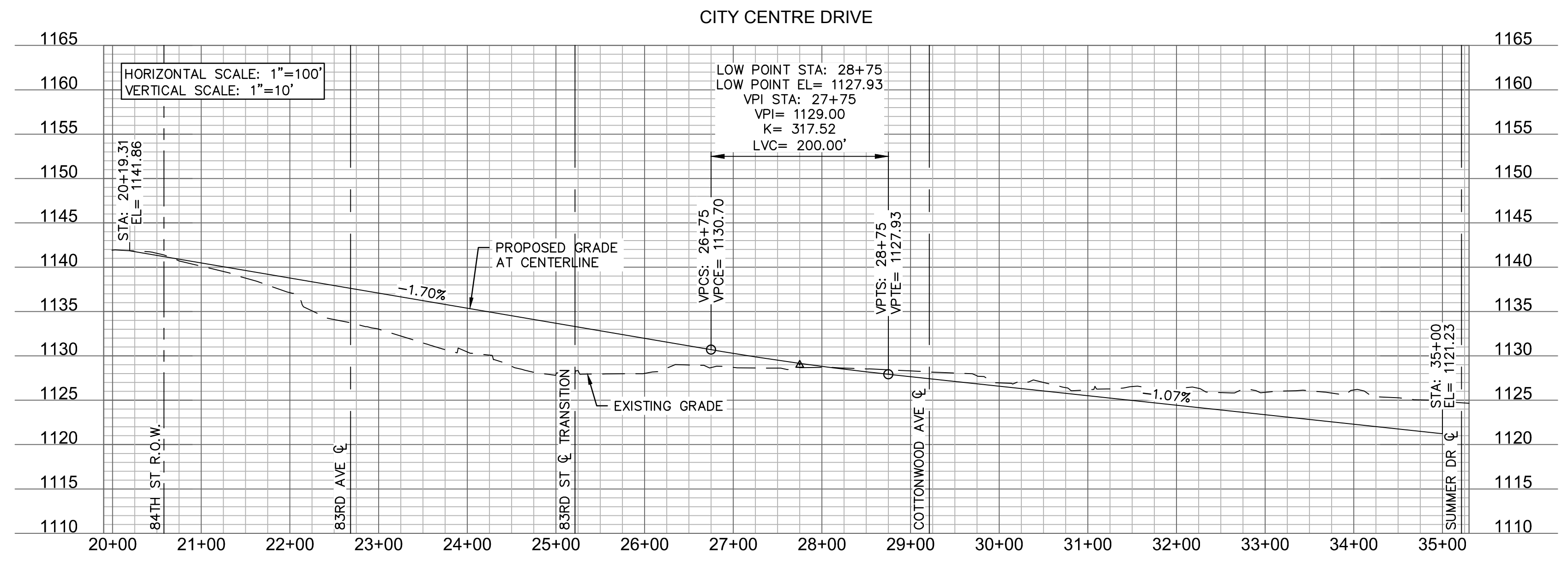
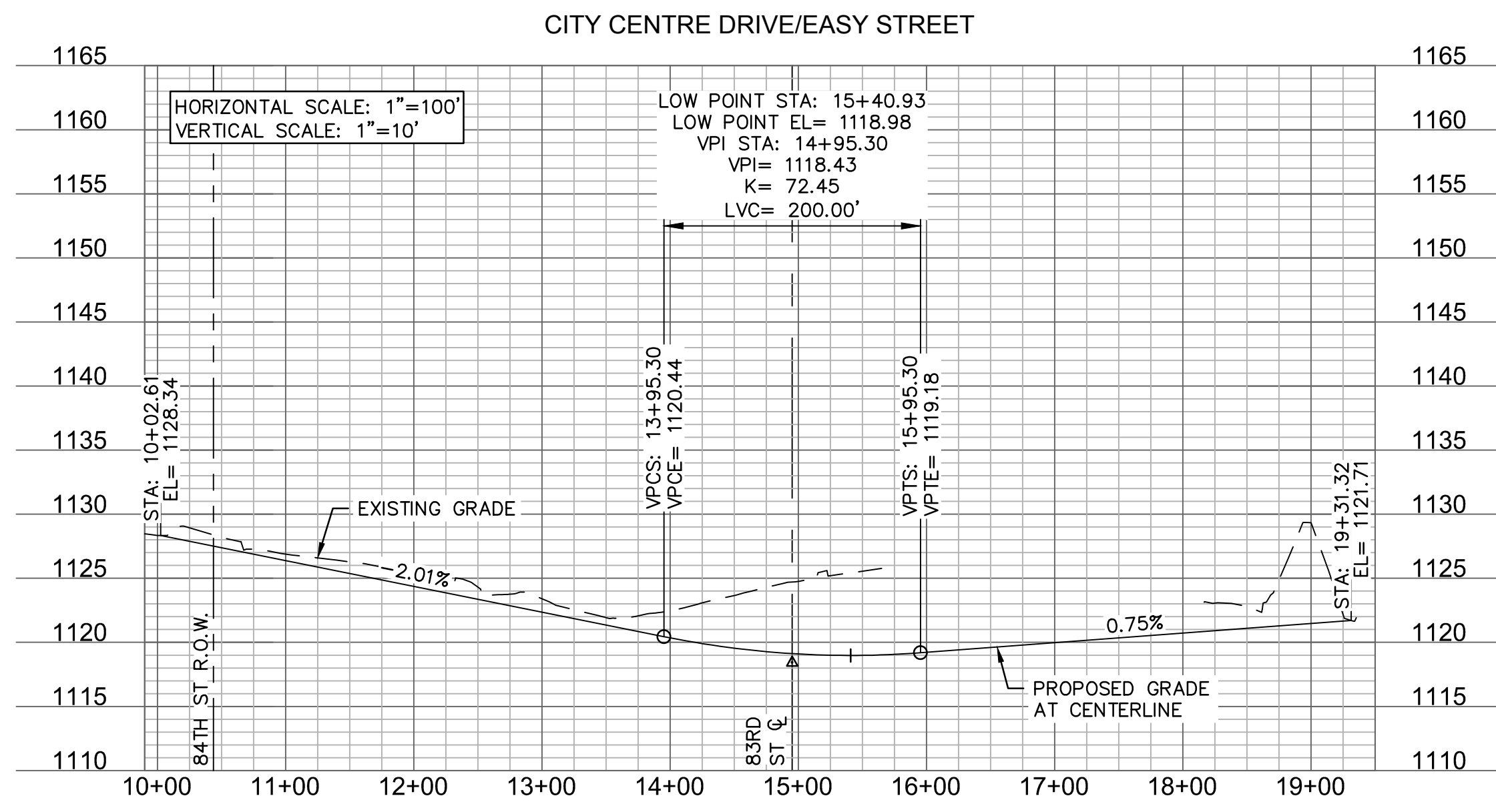

REVISIONS DESCRIPTION

DATE

REV. NO.

REVISIONS

2016

PRELIMINARY CENTERLINE PROFILES

LA VISTA CITY CENTRE
 84TH STREET AND BRENTWOOD DRIVE

LA VISTA, NE

drawn by: CAS
 checked by: ERG
 approved by: ERG
 QA/QC by: ERG
 project no.: 016-0546
 drawing no.:
 date: 04.04.2016